

## Modular Cooking Range Line EVO900 Electric Bain Marie Top Full module

ITEM # \_\_\_\_\_

MODEL # \_\_\_\_\_

NAME # \_\_\_\_\_

SIS # \_\_\_\_\_

AIA # \_\_\_\_\_



392125 (Z9BMEHB000)

Electric bain-marie top with 1  
GN 2/1 well

### Short Form Specification

#### Item No. \_\_\_\_\_

Incoloy armoured heating elements positioned under the base of the well. Used to keep cooked food at serving temperature using hot water inside the well. Water temperature to be controlled by thermostat with maximum temperature of 90 °C. Exterior panels of unit in stainless steel with Scotch Brite finish. Extra strength work top in heavy duty 2 mm stainless steel. Right-angled side edges to allow flush-fitting junction between units.

### Main Features

- Bain Marie used for keeping cooked food at serving temperatures using hot water.
- Incoloy armoured heating elements positioned under the base of the well.
- Knob switch.
- Filling water level is plate-marked on the side of the well.
- Unit to feature manual refill of well.
- Water temperature controlled by thermostat with maximum temperature value of 90 °C.
- Basin drained by drain valve with overflow.
- Special insulation beneath cooking surface keeps heat on the plate without dispersion to the base.
- Unit to have perforated false bottom and runner support for GN containers.
- All major compartments located in front of unit for ease of maintenance.
- The special design of the control knob system guarantees against water infiltration.
- IPX5 water protection.
- Top configuration allows installation on ambient base only (not possible to install on refrigerated nor freezer base).
- Suitable for countertop installation.

### Construction

- All exterior panels in Stainless Steel with Scotch Brite finishing.
- AISI 304 stainless steel worktop, 2mm thick.
- Model has right-angled side edges to allow flush fitting joints between units, eliminating gaps and possible dirt traps.
- Water basin is seamlessly welded into the top of the appliance.
- Unit is 900mm deep to give a larger working surface area.

APPROVAL: \_\_\_\_\_

**Optional Accessories**

- Junction sealing kit PNC 206086
- Support for bridge type installation, 800 mm PNC 206137
- Support for bridge type installation, 1000 mm PNC 206138
- Support for bridge type installation, 1200 mm PNC 206139
- Support for bridge type installation, 1400 mm PNC 206140
- Support for bridge type installation, 1600 mm PNC 206141
- Side handrail for right/left hand PNC 206165
- Frontal handrail 800 mm PNC 206167
- Large handrail (portioning shelf) 800 mm PNC 206186
- Frontal handrail 1200 mm PNC 206191
- Frontal handrail 1600 mm PNC 206192
- Chimney upstand, 800 mm PNC 206304
- 2 side covering panels, height 250 mm, depth 900 mm PNC 206321
- Water filling tap for bain-marie top PNC 921627

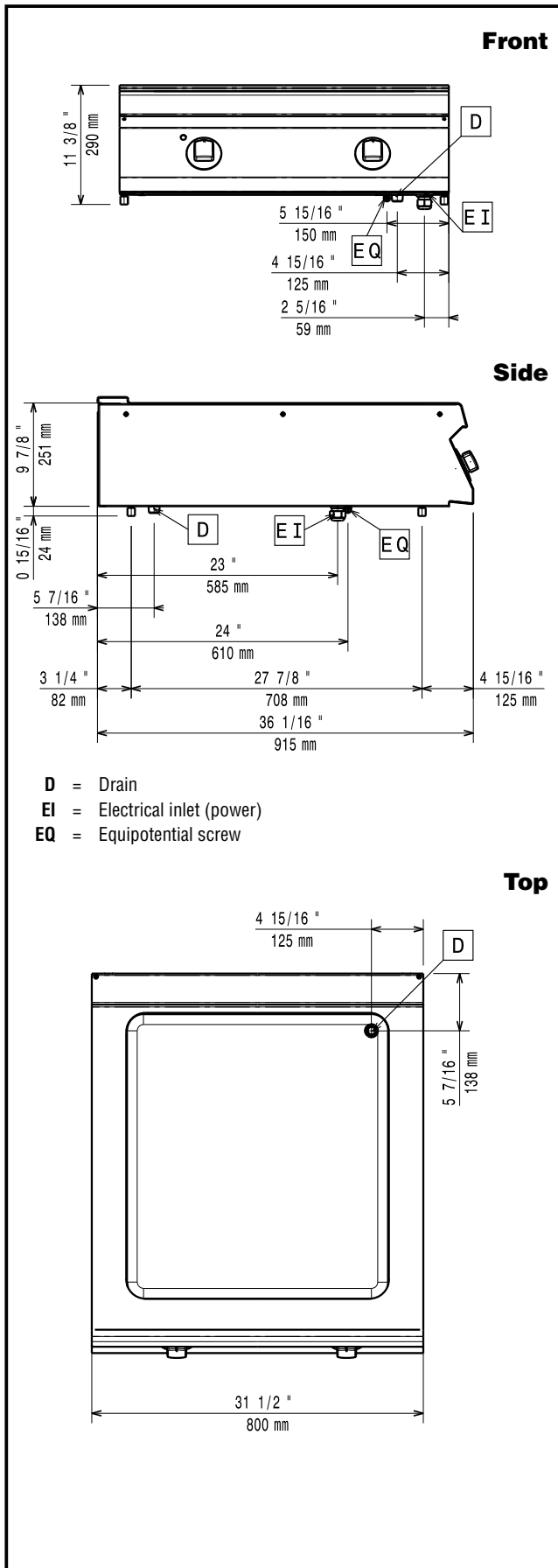

**Electric**

Supply voltage: 380-400 V/2N ph/50-60 Hz  
Predisposed for:  
Total Watts: 4.4 kW

**Water:**

Water Drain: 50 mm

**Key Information:**

Usable well dimensions (width): 630 mm  
Usable well dimensions (height): 160 mm  
Usable well dimensions (depth): 685 mm  
Thermostat Range: 30 °C MIN; 90 °C MAX  
Net weight: 45 kg  
Shipping weight: 45 kg  
Shipping height: 540 mm  
Shipping width: 980 mm  
Shipping depth: 1020 mm  
Shipping volume: 0.54 m<sup>3</sup>  
Certification group: EBM98

If appliance is set up or next to or against temperature sensitive furniture or similar, a safety gap of approximately 150 mm should be maintained or some form of heat insulation fitted.